

Tuesday, July 16, 2024 at 13:51:03 Pacific Daylight Time

Subject: Fw: Korpela Review Set
Date: Tuesday, July 16, 2024 at 1:13:01 PM Pacific Daylight Time
From: Nathan Korpela
To: Jessyca Poole
Attachments: image001.png, image002.png, image005.png, 1718836199386blob.jpg, 1718836247367blob.jpg, 1718836271906blob.jpg

----- Forwarded Message -----

From: Nathan Korpela <nathan4103@yahoo.com>
To: Reed Hardesty <reed206@icloud.com>; Sarah Ford <sarahjford@hotmail.com>
Sent: Wednesday, June 19, 2024 at 03:53:57 PM PDT
Subject: Fw: Korpela Review Set

Hi Reed and Sarah - Following up on my message from a few weeks ago, we have a pretty good civil plan that we are reviewing. You can find it linked below. Please take a look and let me know if you have any questions or comments. Or if you would find it easier to meet together and go over it in person, I'm happy to do that as well. I've already relayed a few suggestions back to the civil engineer regarding the offsite portion of the project including:

**C3.2 - The cross section of the pipe down the slope shows the staking pipe remaining exposed above the top of the pipe [see Snip 1 below]. I'm afraid that could present a future risk of trip or being impaled, especially as those elements are grown over with plants. Can the top of the staking pole be flush with the top of the saddle [see Snip 2]

**C3.1 - See Snip 3. Can we change this from "by homeowner association" to "by the Park Ridge Green Belt Association"

We're hoping to submit for permit in the next month or so. There likely will be some modifications as we go through the permitting process and get input from the city. At some point the city will likely need some sort of documentation showing that the project has permission from the Park Ridge Green Belt Association. We can deal with that now or later. As I mentioned in my prior message, happy to help in any way that I can.

Thank you,
Nathan
206-992-0790 m

Snip 1

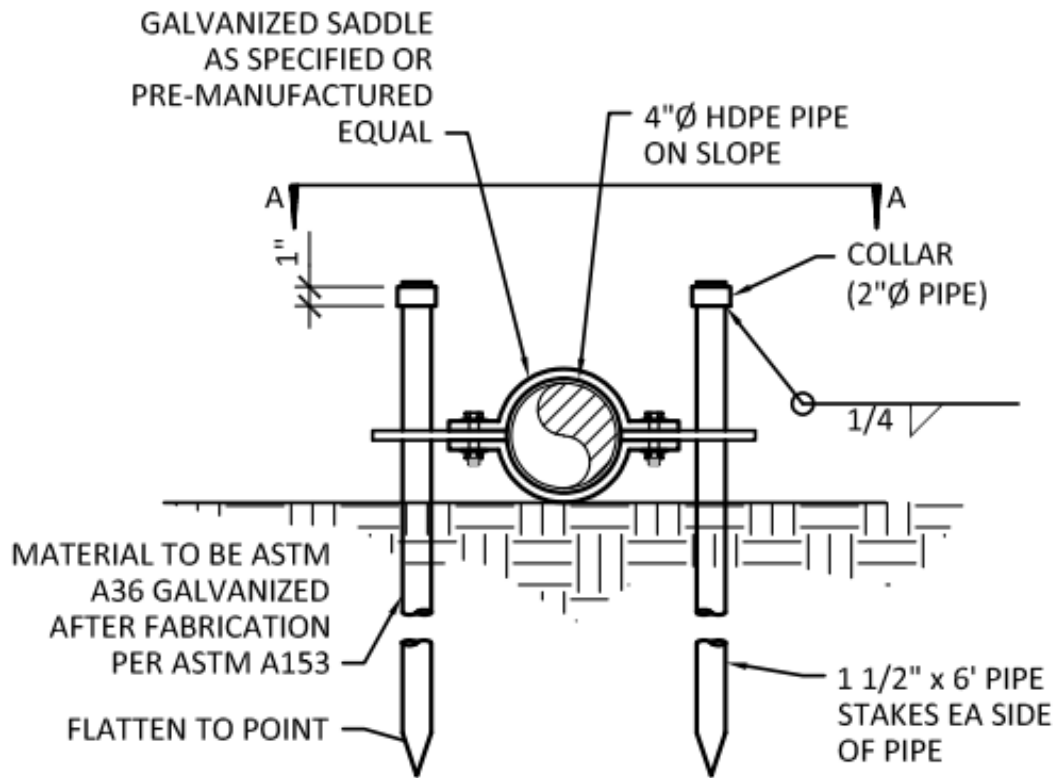

Snip 2

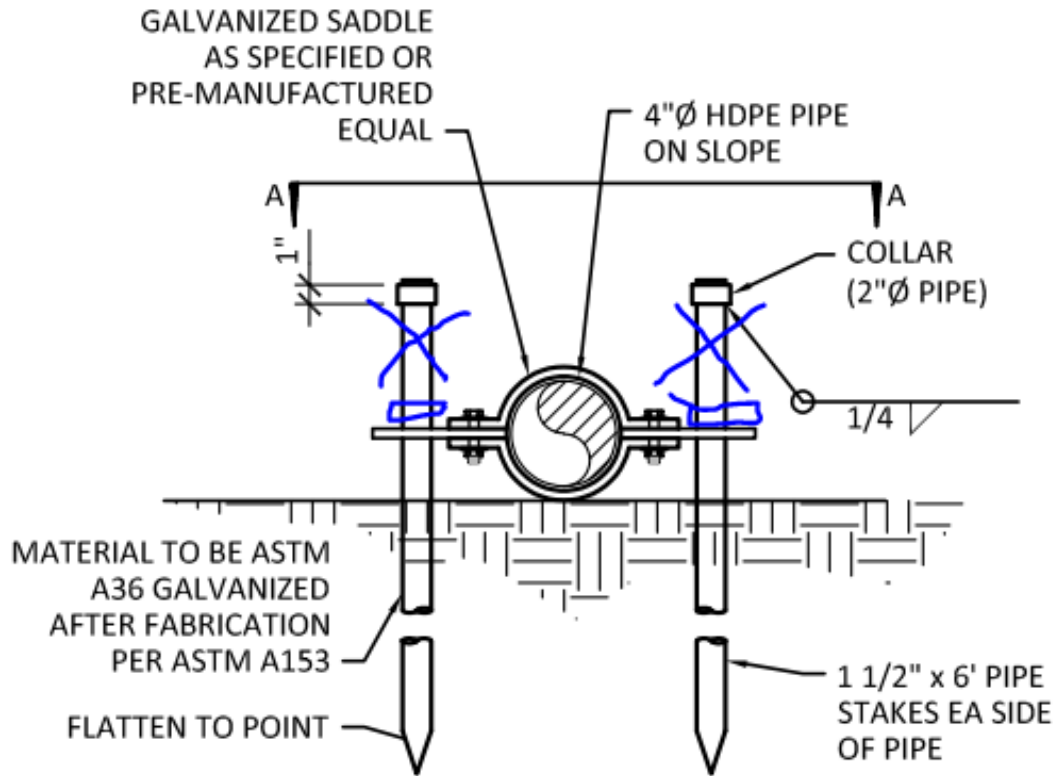

Snip 3

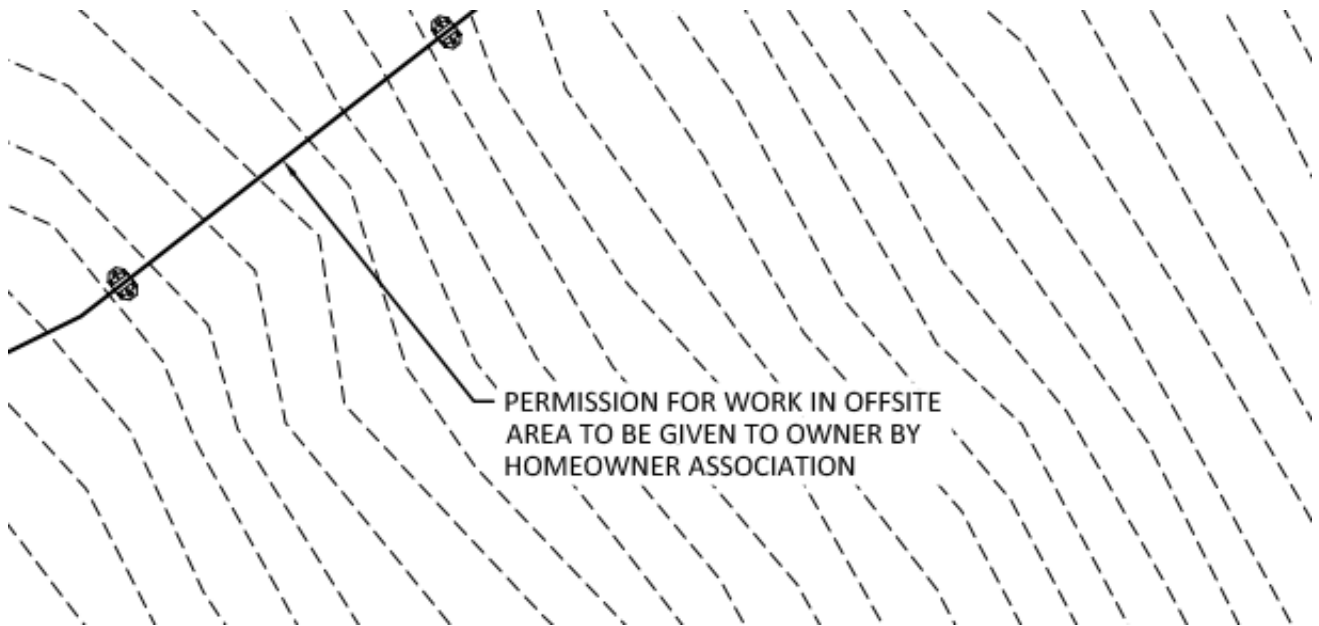

----- Forwarded Message -----

From: Jared Underbrink <jaredu@cgeengineering.com>

To: Nathan Korpela <nathan4103@yahoo.com>; Jessyca Poole <jessyca@poolearchitecture.com>; Benjamin Mark <benmark@salishforest.com>; Dave Williams <dwilliams@zippergeo.com>

Cc: Jacob Olsen <jacobo@cgengineering.com>; Greg Guillen <grego@cgengineering.com>
Sent: Monday, June 17, 2024 at 02:34:12 PM PDT
Subject: RE: Korpela Review Set

Apologies, I work with a Nathan in our office and I didn't catch the autofill!



Jared Underbrink, PE, Senior Project Manager

CG Engineering | p. 425.778.8500 | www.cgengineering.com

From: Jared Underbrink
Sent: Monday, June 17, 2024 2:10 PM
To: Nathan Thompson <NathanT@cgengineering.com>; Jessyca Poole <jessyca@poolearchitecture.com>; Benjamin Mark <benmark@salishforest.com>; Dave Williams <dwilliams@zippergeo.com>
Cc: Jacob Olsen <JacobO@cgengineering.com>; Greg Guillen <GregO@cgengineering.com>
Subject: Korpela Review Set

Hello,

Please see dropbox link. This is labeled as a review set in the subject line but I think we are basically done here.

-I'd like to add the geotechnical report number on C3.1 once it is issued final.

-We also added a bunch of tree info here. Callouts for demo and for existing trees to remain are in the C2 sheets, including the table and protection detail from the Salish Forest reports. In addition we show the new tree locations on C3.1.

-added in Jessica's base plan revision

-ran overland pipe all the way own to channel

-upsized waer service for fire protection

-SSP worksheet is filled out. Once plans are finalized we will have some items to insert between pages in this document.

https://www.dropbox.com/scl/fo/voyxo6t426rxvmrp1nhln/AMrmzqyGcT_CfOQsYkIHcC4?rlkey=vdqk3gos3jjw4j8d3e7j6lfdx&st=5q48hbso&dl=0

Thanks,



Jared Underbrink, PE, Senior Project Manager

CG Engineering | p. 425.778.8500 | www.cgengineering.com